

**SIMULATION AND PARAMETER ANALYSIS OF POWER QUALITY PROBLEMS MITIGATION IN GRID CONNECTED SOLAR-WIND SYSTEM****Mr. Chaitanya Patel**

Ph.D. Scholar, Department of Physics, Mehsana Urban Institute of Science, Ganpat University, Kherva, Mehsana, Gujarat, India

**ABSTRACT**

*The advantages of solar and wind energy generating are combined in a hybrid power plant to generate electricity. The purpose of installing solar panels is to harness the photovoltaic effect of sunlight to generate power. In order to capture wind energy and transform it into electrical energy, wind turbines are built. The ability of a hybrid system to produce electricity even when one of the sources—solar or wind—is not operating at its best is one of its main advantages. When output exceeds demand, hybrid systems can be connected to the electrical grid, exporting excess power to the grid and consuming power from it when production is insufficient. The output voltage of solar panels and wind turbines can fluctuate due to variations in solar radiation and wind speed. These variations may result in voltage sags or swells in the power system due to voltage instability. Storms, strong gusts, and dense clouds are examples of extreme weather conditions that can stop the production of solar and wind energy. This may result in brief blackouts or decreased power output, which would compromise the power supply's dependability. A mix of advanced control strategies, grid integration tactics, and the application of power conditioning equipment including voltage regulators, energy storage systems, and active filters are needed to address these power quality challenges. This paper is describing the power quality issues and its mitigation technique using MATLAB/simulation tool. The parameters of hybrid power system of solar-wind are analysed based on simulation.*

*Keywords- RES, Solar PV, Wind, Grid, Power Quality, Harmonics , MPPT.*

**INTRODUCTION**

India has the size of a continent, and by integrating it into national grids, it helps balance the erratic production of renewable energy sources in a few states. RES generated 24914 MW of grid interactive electricity as of March 31, 2012, or around 12.1% of the installed energy capacity. Furthermore, by 2022, the Indian government's Ministry of New and Renewable Energy (MNRE) hopes to generate 20000 MW of grid-interactive solar power and 38500 MW of wind power. Wind and solar energy, which have been growing more quickly over the past two to three decades, are the main components of renewable energy sources (RES). Recent years have seen a sharp increase in the amount of renewable energy from solar and wind, which now makes up a significant share of grid power. Because solar PV radiation and temperature vary, it is necessary to regulate the output of solar PV to maintain a steady level. This paper presented various boost converter circuits and MPPT (Maximum Power Point Tracking) algorithms for PV application operation. The boost converter's duty cycle regulation is provided via the MPPT algorithm. P&O, INC, fuzzy logic control, and other solar PV applications use various forms of MPPT algorithms. I developed the MPPT algorithm for my boost converter control with my supervisor's assistance. PWM receives the duty cycle signal from MPPT to initiate the boost converter's pulse control.

PWM receives the duty cycle signal from MPPT to initiate the boost converter's pulse control. The need for power that surpasses a nation's capacity to generate it Here, renewable energy sources like wind and PV power are used to supplement fossil fuel-based power generation. However, because of the non-linear load that results from the rectifier and RL load, there is some distortion in the load current. Thus, in this case, active power filter reduction and harmonic and reactive power compensation can be achieved at the same time by employing a voltage source inverter linked in parallel. In order to lessen the current distortion in the load current, an active power filter produces compensating current that is equivalent to the harmonic current but opposing in phase.

Combining a shunt filter and a series filter, an active power filter produces a compensatory current of the same magnitude and opposite phase to the non-linear loads in the harmonics that are present.

Significant power quality issues occur in power system which are dangerous to system operation are listed as under.

- Sag/swell
- Harmonic distortion at terminals
- Voltage unbalance (overvoltage/undervoltage)
- Flickers, fluctuation
- Electromagnetic interruption

The many power quality issues listed above can be resolved in a power system or distribution system by using a universal active power filter, which has an outstanding efficiency and quick detection action.

### SOLAR PV SYSTEM

A solar photovoltaic (PV) system uses semiconductor materials to directly convert sunlight into electricity. Many solar cells combine to form solar panels, also known as solar arrays. The most common material for these cells is silicon, but they can also be formed of thin-film materials or cadmium telluride. Electricity is produced when sunlight strikes the solar cells, exciting the electrons. produces a direct current of electrons that is then sent into an inverter circuit for use in a home application to change the direct current to an alternating current (AC).

### SOLAR PV SYSTEM WITH MPPT

There are two types of solar PV system existing in operation of power system viz, PV system with MPPT(Grid connected) and stand-alone solar PV system (off-grid). Working of Grid connected in two stages is explained as under.

**Stage-1:** -Here Grid connected PV system is connected to DC-DC boost converter first & then fed to a DC-AC converter.

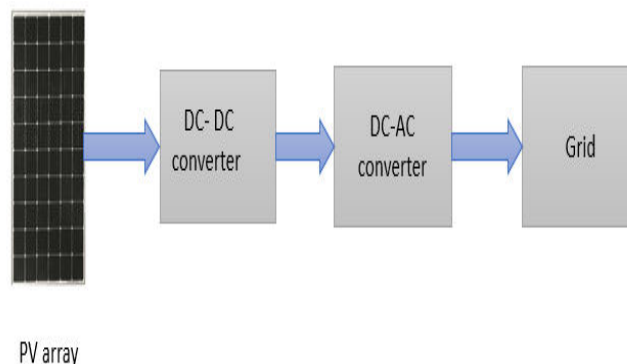
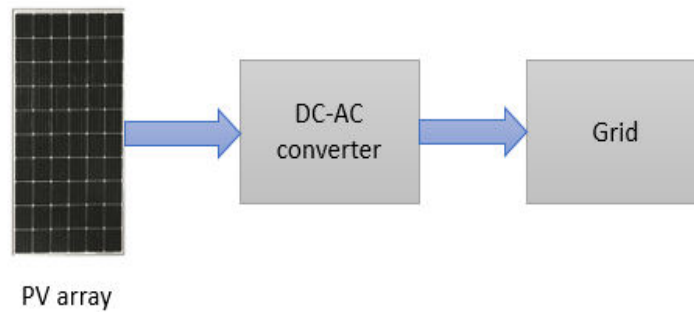

**Fig.1** Grid integrated Solar PV system and its stages

This system is connected to the grid side and uses an inverter and boost converter circuit. Grid connectivity allows PV systems to operate in parallel with standard electricity distribution systems. Power loads can get power through the grid or available sources.

**Stage-2:** - DC-AC converter & the grid connection stage.

Yet, the grid-integrated photovoltaic system with an inverter and DC-DC converter is recommended. DC-AC converters are helpful for power bus control and noise isolation.



**Fig.2** Grid integration PV system with DC-AC converter

### STAND-ALONE SOLAR PV SYSTEM (OFF GRID)

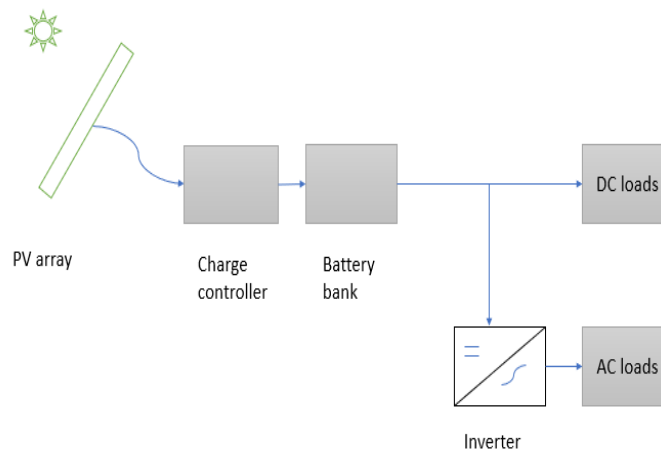

**Fig.3** PV system is stand-alone (off grid)

A stand-alone photovoltaic system functions autonomously, but other power sources can be used to supply electricity to specific loads, such as battery banks, for use at night or when sunshine is scarce. Since autonomous systems can operate independently of other power sources, standalone systems also frequently use them.

### WIND POWER

In recent years, one of the markets for wind power generation with the quickest rate of growth has been India. India had about 39 GW of installed wind power capacity as of 2021.

With the goal of achieving 60 GW of installed wind power capacity by 2022 and 450 GW of renewable energy capacity by 2030, the nation has set lofty ambitions for increasing its renewable energy capacity, including wind power. Global installed wind power capacity exceeded 750 GW as of 2021.

Investing in wind power generation is a common strategy used by many nations to cut greenhouse gas emissions, fight climate change, and attain energy independence. In general, a crucial element of their energy transition plans, which seek to boost the penetration of renewable energy, is to give priority to wind power generation.

Grid integration is necessary in order to ensure that the consumer solar-wind hybrid system's load demand is met by continuous output generation. The solar-wind hybrid system is utilized with the BESS as an energy backup. Figure-4 is showing block diagram of proposed working system.

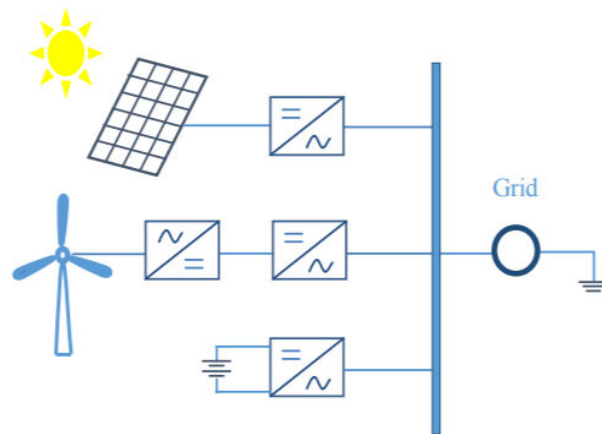

**Fig.4** Solar PV-Wind Hybrid system

**POWER QUALITY ISSUES**

The imbalance in voltage, current, and frequency caused by equipment malfunction or failure makes the power quality issue problematic. Modern electronics need different amounts of electricity and power than traditional appliances. The increased usage of switching devices, nonlinear loads, sensitive loads, maximum utilization and rise in demand of power electronics switching devices, etc. are the causes of the power quality issues and their consequences.

**Harmonics**

In a power system, harmonics are variations from the alternating current waveform's fundamental frequency, which is usually 50 or 60 Hz. These variations, which appear as multiples of the fundamental frequency, have the potential to cause electrical system disruptions and inefficiencies. Within the power system, harmonics can come from a variety of sources, including nonlinear loads like arc furnaces, power electronic converters, electronic devices, and adjustable speed motors. The voltage and current waveforms are altered as a result of these loads drawing non-sinusoidal currents. Harmonics can negatively impact equipment and power systems in several ways.

Figure-5 is showing various harmonics sources which are most common in power system.

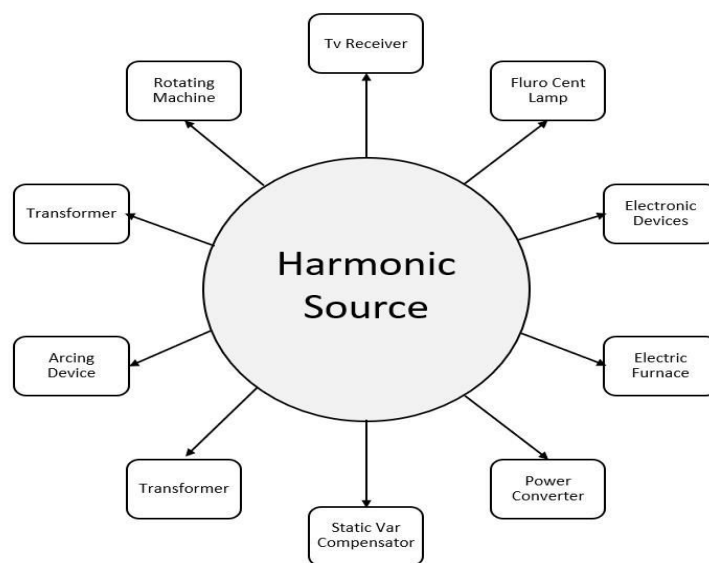

**Fig.5-** Harmonics source

### Effects of Harmonics

- Increased losses resulting from additional heating brought on by harmonic currents in transformers, motors, and other equipment.
- Voltage distortion can result in lower power quality, equipment malfunction, and false protection device tripping.
- Interference with delicate electronic equipment, control systems, and communication networks.

Because of this, a pure sine wave of voltage or current has neither distortion nor harmonics, while a non-sinusoidal wave has. The term used to measure the distortion is Total Harmonics Distortion (THD).

### Total Harmonic Distortion (THD)

Total harmonic distortion (THD), which represents the ratio of the root mean square (RMS) value of the harmonic content to the RMS value of the fundamental frequency, is one measurement used to quantify harmonic distortion. Harmonic components in power systems are found and examined using harmonic analysis equipment, such as oscilloscopes and power quality analysers. Below equation is for calculation of current/voltage.

$$THD = \frac{\sqrt{\sum_{h>1}^{h \max} M^2 h}}{M_1} \quad (1)$$

Here  $M_h$  is RMS value of harmonic component of the quantity  $M$ . The RMS value of a distorted waveform is the square root of the sum of the squares as shown in Eq. (1) and (2). The THD is related to the rms value of the waveform as follows:

$$\begin{aligned} RMS &= \sqrt{\sum_{h=1}^{h \max} M^2 h} \\ &= M_1 \sqrt{1 + THD^2} \end{aligned} \quad (2)$$

Although the THD is a highly helpful metric for many applications, one must be aware of its limits. It can give a fairly accurate estimate of the additional heat that will be generated when a distorted voltage is placed across a resistive load. It can also indicate any additional losses brought on by the current passing through a conductor.

**Voltage Sags:** The most frequent power issues with power systems are voltage sags. Sags, which are transient voltage drops of 10–90% of the average voltage, can disrupt fragile components like robots, relays, and variable speed drives. The most common causes of sags include high-rated motors being started, capacitors switching, and fuse or breaker action. Recloser operation usually causes voltage sags to be non-repetitive or to reoccur only a few times. Voltage swells on one phase or several phases may accompany sags on one or more phases.

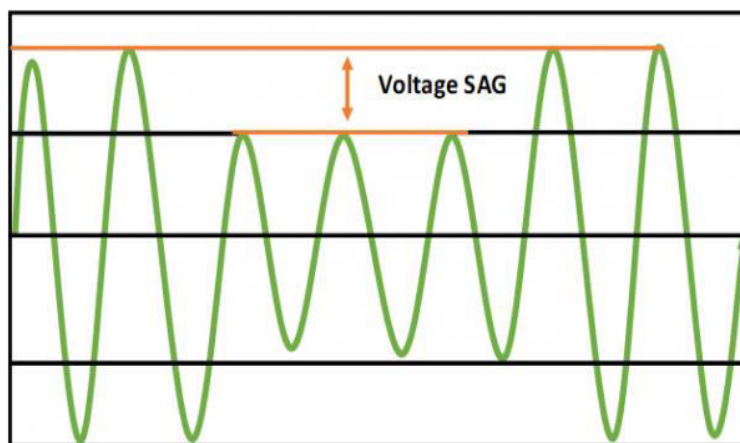

**Figure 6:** Voltage sag waveform

**Voltage Swells:** Swell, which happens on the healthy phases of a three-phase system during a single line-to-ground fault, is an RMS increase in the AC voltage at the power frequency for periods ranging from a half-cycle to a few seconds. The system grounding is connected to the swell's magnitude. A loose or damaged neutral connection, excessive reactive power compensation, or a rapid drop in load on a circuit with a subpar or damaged voltage regulator are the most common causes of voltage swells.

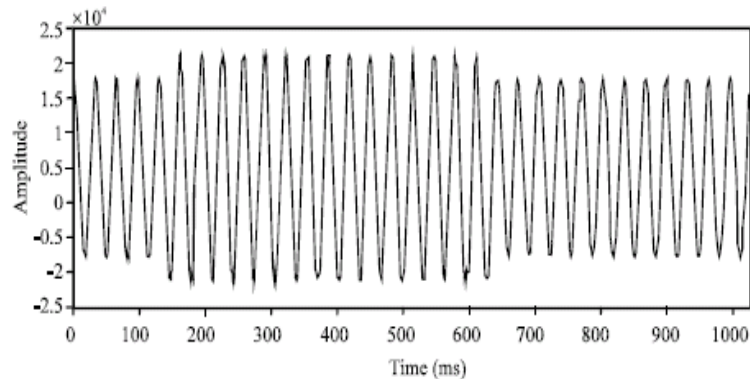

**Figure 7:** Voltage Swell waveform

**Power Interruption (Momentary):** Equipment failures, recloser operations, and transmission outages can all result in power disruptions, which are zero-voltage occurrences. Usually brief in nature, interruptions might happen throughout one or more phases. A significant proportion of power outages last less than 30 seconds.

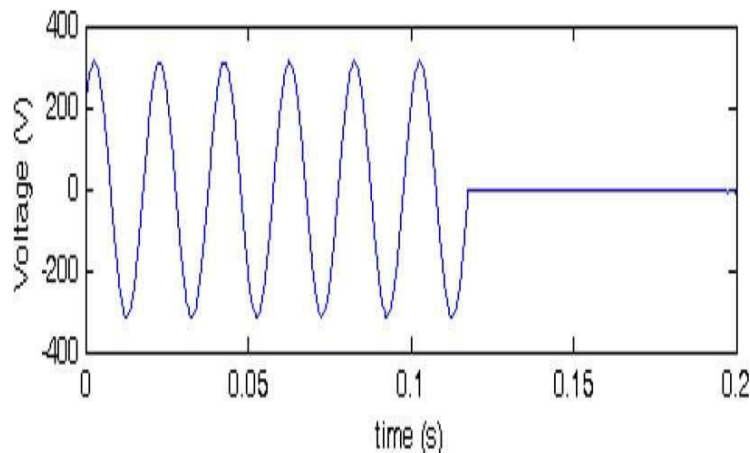

**Figure 8:** Power interruption waveform

## SIMULATION AND RESULT DISCUSSION

### Hybrid of Solar-Wind Using $V_L$ - $V_P$ Control Method

We have completed the Matlab simulation of a solar-wind hybrid system using the phase-and line-voltage control approach in this section. This hybrid system includes both solar and wind power with MPPT. The inverter is controlled by  $V_L$ - $V_P$ , and the hybrid output voltage and current are displayed with grid synchronization.



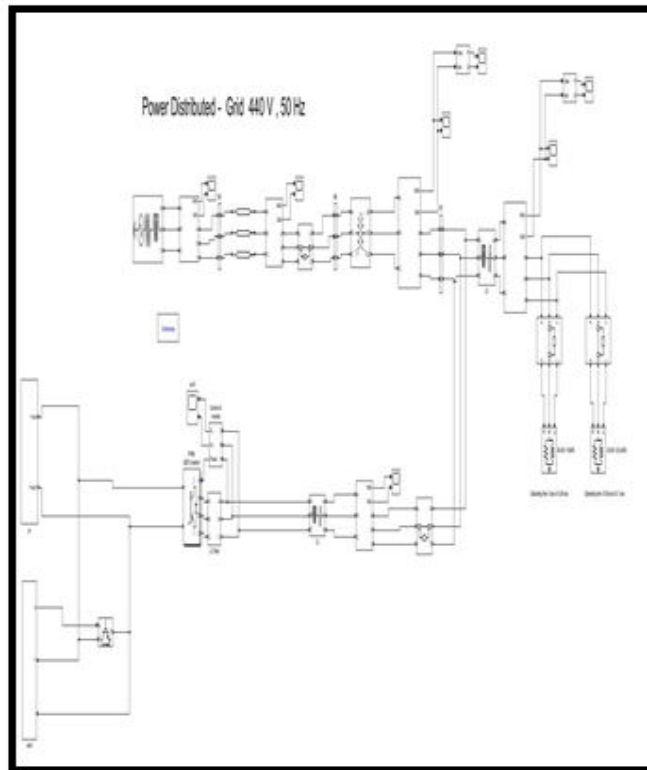

Fig 9 Main Hybrid system with closed loop grid integration

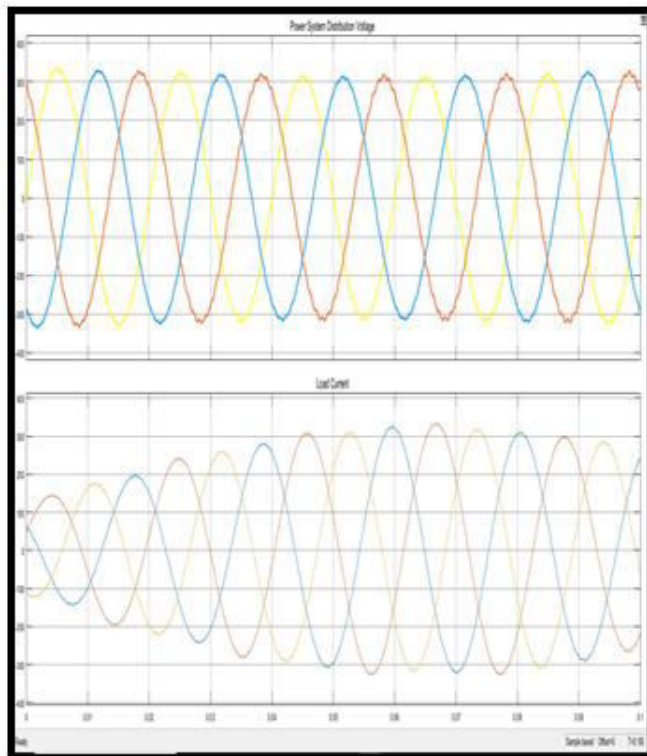
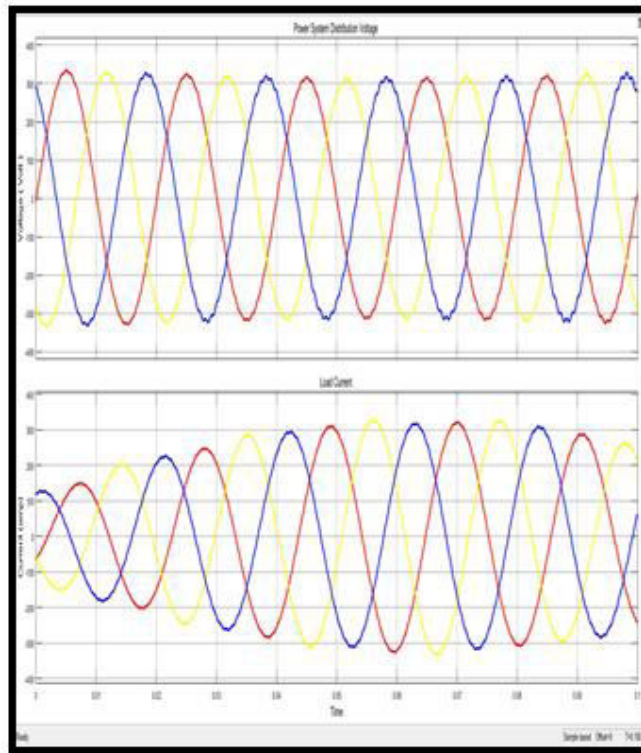
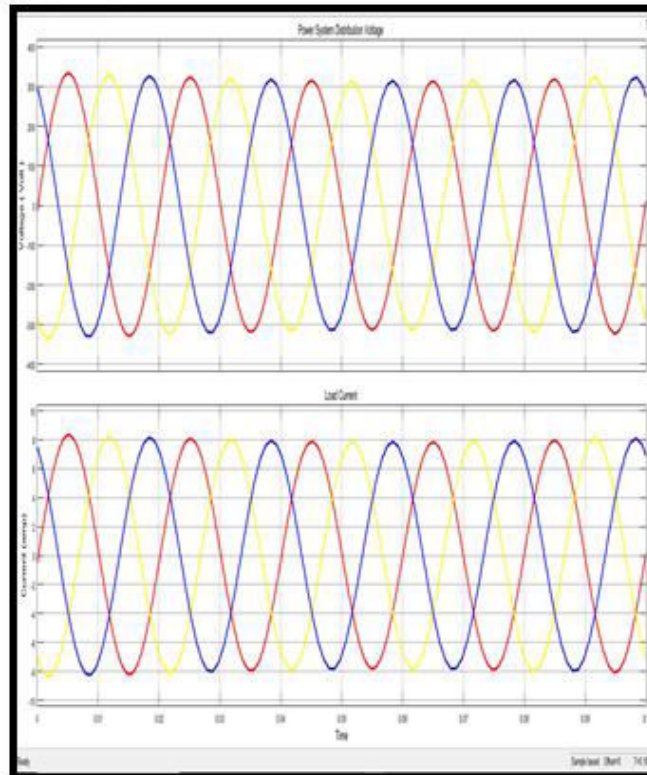

Fig 10: Distribution side hybrid output Voltage and Current

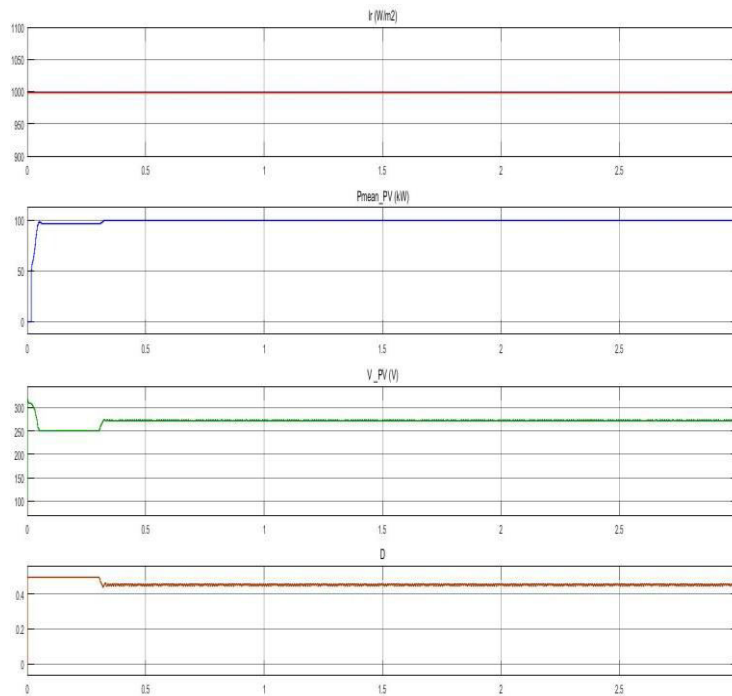

**Fig 11-** Grid Supply side voltage and current



**Fig 12:** Load side voltage and currentpower at Load Side





**Fig 13-** Solar PV output Parameters

## V. CONCLUSION

A hybrid wind/photovoltaic energy system for freestanding systems is presented in this research. One energy source is inferior to a solo hybrid system. Due to their higher unpredictability compared to solar energy and their low wind speeds, wind energy systems might not be technically feasible at every location. Thus, it is becoming more and more appealing to use various renewable energy sources together. The future improvements that could make these systems more user-accepted and economically appealing are also highlighted in this paper. Additionally, this paper uses MATLAB-SIMULINK software to model and simulate a solar PV system. The optimal I-V and P-V characteristics of the solar PV system are displayed by the simulation results. The simulation results also display the three-phase output voltage of the wind power facility. This study successfully completes the grid integration and synchronization of the solar-wind hybrid system.

## REFERENCES

- [1] Akshay S. Shirbhate, and Prof. Suhas D. Jawale, "Power Quality Improvement in PV grid Connected system by using Active Filter", 978-1-4673-9925-8/16/©2016 IEEE.
- [2] Yashi Singh, Ikhlq Hussain, and Bhim Singh, Sukumar Mishra, "Power Quality Improvement in Single Phase Grid Tied Solar PV-APF Based System using Improved LTI-EPLL Based Control Algorithm" 2017 7th International Conference on Power Systems (ICPS) College of Engineering Pune, India. Dec 21-23, 2017, 978-1-5386-1789-2/17/©2017 IEEE.
- [3] Sachin Devassy, and Bhim Singh, "Implementation of Solar Photovoltaic System with Universal Active Filtering Capability" IEEE Transactions on Industry Applications, 0093-9994 (c) 2018 IEEE.
- [4] Satyavarta Kumar Prince, Kaibalya Prasad Panda, Moushumi Patowary, and Gayadhar Panda, "FPA tuned Extended Kalman Filter for Power Quality Enhancement in PV integrated Shunt Active Power Filter", 2019 International Conference on Computing, Power and Communication Technologies (GUCON) Galgotias University, Greater Noida, UP, India. Sep 27-28, 2019, 978-93-5351-098-5/19/2019 Galgotias University.

- [5] M T L Gayatri, Alivelu M Parimi, "Power Quality Improvement of PV-WECS Microgrid Using Active Power Filter in Real time", 978-1-5386-2910-9/18/2018 IEEE.
- [6] Asmae Azzam-Jai and Mohammed Ouassaid, "Power Quality Improvement of a Photovoltaic Active Power Filter using A Fuzzy Hysteresis Band Current Controller", 978-1-7281-5152-6/19/ ©2019 IEEE.
- [7] Krishna kumar S, Ranga J, Ch.S.K.B.Pradeep Kumar and Jayalakshmi S, "PV based Shunt Active Power Filter for harmonics mitigation using Decoupled DSRF theory", 2019 5th International Conference on Advanced Computing & Communication Systems (ICACCS 2019), 978-1-5386-9533-3/19/©2019 IEEE.
- [8] Rachid Belaidi, Mohamed Fathi, Mohamed Mgezzi Larafi, Gunia Mohand Kaci, Rachid Belaidi, A. Haddouche, "Power Quality Improvement Based on Shunt Active Power Filter Connected to a Photovoltaic Array", 978-1-4673-7894-9/15/ ©2015 IEEE.
- [9] Hamza Afghoul, Fateh Krim, Antar Beddar, Badreddine Babes, "Real time Implementation of Robust Controller for PV Emulator Supplied Shunt Active Power Filter", 978-1-7281-1182-7/18/ ©2018 IEEE.
- [10] Soumya Ranjan Das, Prakash. K. Ray, Asit Mohanty, "Power Quality Improvement using grid interfaced PV with Multilevel inverter based hybrid filter", 978-1-5386-4844-5/18/ ©2018 IEEE.