

Improving The Design of Parabolic Dish Engine by Adjusting the Focal Point for Indirect Illumination Receiver

DwiRahmalina, Reza Abdu Rahman, Octavian Yudhistira, Agri Suwandi
 Department of Mechanical Engineering, Faculty of Engineering, Universitas Pancasila, Jakarta, Indonesia
 Corresponding author: drahmalina@univpancasila.ac.id

Date of Submission: 10th June 2021 Revised: 30th July 2021 Accepted: 28th August 2021

Abstract - CSP systems operate with thermal energy storage (TES), which considers cost-effective storage than battery systems for solar PV. The parabolic dish has the highest concentration ratio and working temperature (up to 700 °C). Unfortunately, the direct receiver makes the application of parabolic dish is limited. Adopting the same principle with the others CSP models, it is possible to implement an indirect receiver for a parabolic dish. Through design modeler, it shows that direct receiver is possible to use in parabolic dish system. Furthermore, the ideal receiver position can be adjusted by applying z based on the dimension of the receiver. It finds that placing the receiver precisely at the focal point shows unsuitable heat absorption where the surface temperature of the receiver is 200 – 270 °C. Adjusting the receiver below and above the focal point ($+z$ and $-z$) indicates a better heat absorption where the temperature on the receiver is 300 – 360 °C and 420 – 500 °C. The proposed design can be taken as a new approach to improve the parabolic dish system.

Index Terms - Dish engine, Indirect illumination receiver, Parabolic dish, Vertex point

I. INTRODUCTION

The potential of renewable energy as an alternative energy source is continuously improved to meet the demand of global energy consumption [1], [2]. Solar energy is the best option because of its abundant availability, predictability, and able to meet the global energy demand. Concentrated Solar Power (CSP) application to harvest solar energy provides a broader opportunity to use the system for electrical generation and heating applications [3]. The parabolic dish system is considered the ideal model for broad implementation with the highest concentration ratio and working temperature among all CSP models. However, it still needs to be improved to reach a mass-production scale.

The parabolic dish system works by reflecting the sunlight from the dish concentrator to the focal point where

a receiver can absorb the concentrated heat energy from the sunray. The heat engine (commonly Stirling engine) is paired with the receiver, converts the heat to electrical energy; that is why the parabolic dish is also called a dish engine or dish Stirling system [4]. Unfortunately, putting the heat engine at the receiver has many disadvantages [5]. The design is complex, requiring particular components to support the receiver (cantilever), difficult to manufacture, and overweighted. The operation is also limited because of the absence of thermal energy storage. All disadvantages make the system is uneconomically feasible [6].

Research and further development have been made and continue on the system since the parabolic dish is considered the ideal CSP model [7]. The research and development are mostly done to increase the system's overall efficiency and propose a new configuration to simplify the design. The CSP system can work continuously (day and night) using thermal energy storage [8]. It is well known that thermal energy storage is cheaper and safer than storing energy in the electrical form (photovoltaic system). The basic parabolic dish model does not allow thermal energy storage because the system uses a direct illumination receiver. Thus, the system can be improved by applying the indirect illumination receiver (IIR). The successful application of IIR can be seen in the other CSP system, such as parabolic trough collectors (PTC) [9] and solar towers [10], where both systems have reached the commercial stage and have been used for large electricity production.

There is limited literature that discussed the application of IIR in a parabolic dish as a whole system. For instance, Soltani et al. [11] focus on the design of the cavity for IIR and where the thermal performance of the system can achieve up to 65%. O. López, et al. [12] focused on the cavity in a parabolic dish for low-medium temperature, including solar tracking system, and found the overall thermal efficiency of the system is increased, but the piping system for HTF (Heat Transfer Fluid) is too long which increased the convection heat losses. Though so, by using IIR, the overall thermal efficiency of a parabolic dish is generally better than direct illumination receiver [13].

This study is proposed a new configuration for a parabolic dish system by using an Indirect Illumination Receiver. Proposing a new design is a broader topic since it aims to share knowledge among the researcher by providing a new superior design for the parabolic dish system in CSP application. Then this study is focused on the adjustment for finding the ideal receiver position since it will affect the absorbed heat on the receiver. Furthermore, we propose a new mathematical approach for adjusting the suitable receiver position because it is one of the critical issues in the parabolic dish system. It directly affects how much the system can absorb the reflected sunray from the reflector. The mathematical approach is analyzed through geometrical modeling and evaluated experimentally to verify the result. The finding on the research is expected to provide an essential reference regarding the new design for the IIR parabolic dish and the receiver position adjustments that other researchers can adapt to maximize the performance of the parabolic dish system, both for the direct and indirect receiver.

II. METHOD AND MATERIALS

2.1. Modelling the Indirect Illumination Receiver

The main components of an indirect illumination receiver for the parabolic dish are identically similar to the direct illumination receiver. The basic parabolic dish system is equipped with a dish concentrator, solar tracking system, receiver (absorber), and cantilever beam for the heat engine (located in the dish's focal point). The basic design prevents the utilization of thermal energy storage due to limited space, and also, adding extra components on the receiver will increase the load.

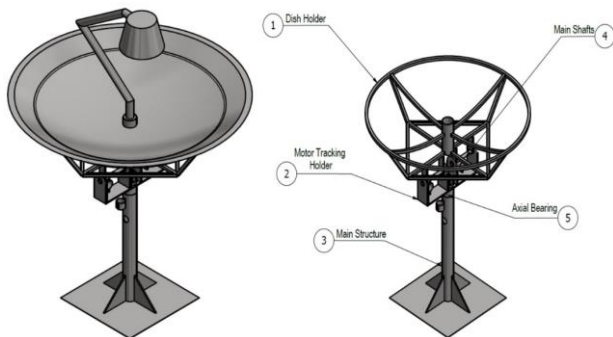

FIGURE 1.

THE PROPOSED NEW DESIGN FOR IIR PARABOLIC DISH

The parabolic dish system with an indirect illumination receiver allows an extended application to utilize the collected thermal energy. The collected heat at the receiver is absorbed by the Heat Transfer Fluid (HTF) and distributed through a piping system, where the heat can be stored in thermal energy storage and various heat engine can be used (i.e., Brayton cycle or a heat exchanger for heating application). It allows to use of a simplified component, hence reduce the cost.

After conducting an in-depth literature review and focusing to the IIR parabolic dish design development, we created an advanced design for the IIR parabolic dish that can work effectively by considering all the factors in the ideal parabolic dish system. The proposed model of the developed dish system is shown in Figure 1.

2.2. Experimental Validation

The compact structure on the offered design makes it easy to install, minimizing the cost for assembly and material for construction and maximizing the heat absorption by controlling the flow during day and night operation. As the first design consideration, the study is focused on the receiver position as the critical parameter that needs to be solved because it is still a complicated issue for a parabolic dish to put the ideal receiver position.

TABLE I
DISH GEOMETRIES

Items	Value
Diameter dish	1,850 mm
Focal length (f)	713 mm
Effective aperture area	2.89 m ²
Focal point position	Center
Dish material	Galvanized sheet
Structure material	Carbon steel
Dish mass	15.2 kg
Rim angle (ψ)	66°
Items	Value
Diameter dish	1,850 mm

The detailed geometry of the dish is shown in Figure2 and Table I. Using a satellite dish makes it easy to determine the initial reference design for the parabolic dish system, and also it is considered lightweight, cheap and affordable [14], [15].

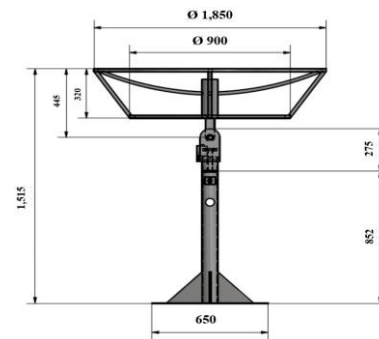

FIGURE 2.

STRUCTURAL GEOMETRY FOR THE NEW DESIGN FOR IIR PARABOLIC DISH SYSTEM

Changing the receiver position affects the concentration ratio from the collector. Different levels of solar concentration will cause the temperature received by the receiver to vary. For validation, three different identic dishes were made and tested simultaneously to ensure the same solar radiation at a given time. An aluminum sheet coated with high-absorbing material is used as a receiver to absorb

the oncoming reflected sun from the concentrator. A high-temperature laser thermometer was used to measure the surface temperature on the receiver.

III. RESULTS AND DISCUSSION

3.1. Modeling the Indirect Illumination Receiver

Typically, the position of the receiver depends on the focal point of the dish. The concentration ratio can be determined by referring to Eq. (1) [16]:

$$C_{max,2-ax} = \left(\frac{\sin\psi_{rim}}{\sin\theta_{sun}} \right)^2 \quad (1)$$

The half-angle divergence angle of sunlight on earth (θ_{sun}) is 0.275° , then the concentration ratio value on the proposed design is 36,815 (based on dish dimension as appears in Table 1).

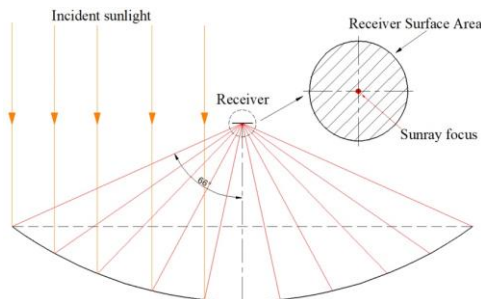

FIGURE 3.

SCHEMATIC MODEL FOR REFLECTED SUNLIGHT ON DISH CONCENTRATOR

The receiver's position is generally placed precisely at the focal point. Figure3 shows the schematic model of the reflected sunray when the receiver is located precisely at the focal point. The focused sunray on the receiver only occupied a small area since the receiver is located precisely at the focal point. It causes a significant decrease due to limited heat absorption on the receiver surface.

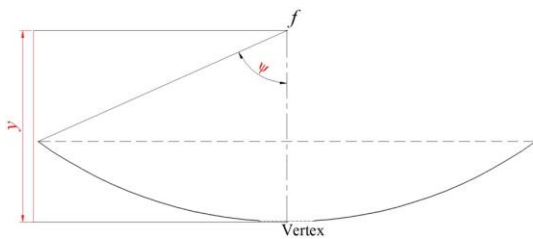

FIGURE 4.

BASIC 2D GEOMETRY OF THE CONCENTRATOR DISH

It is done by adjusting the relative angle between the receiver and dish concentrator to prevent losses. Typically, the receiver is tilted to the area with the optimum reflectance. The method is only suitable for the direct illumination receiver. Moreover, it has a side effect where the receiver only receives partial reflectance from one side [17]. We offer a new approach for determining the optimal receiver position by adjusting the receiver position based on

the parabolic vertex line, which can be used both direct or indirect illumination receiver.

Considering the basic geometrical model (Figure4), where y is the distance between the vertex and the focal point (f) and ψ is the rim angle. The position of the receiver can be adjusted using the detail geometry in each dish (y and ψ). Changing the relative angle makes a partial absorption on the receiver. As a new approach, the receiver can be set above or beneath the focal point to maximize sunlight's absorption from all directions. Figure5 shows the receiver position's new adjustment where in Figure5A, the receiver position is set beneath the focal point and Figure5B is above the focal point.

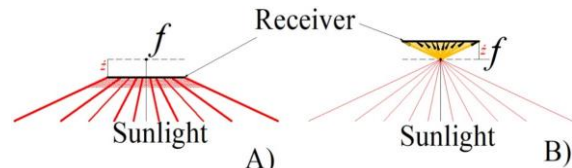

FIGURE 5.

GRAPHICAL ILLUSTRATION FOR RECEIVER POSITION: A) BENEATH THE FOCAL POINT, B) ABOVE THE FOCAL POINT

As seen in Figure5, a new adjustment for the receiver position shows that the two models (beneath (A) or above (B) the focal point) can receive the reflected sunray from the dish concentrator for the entire receiver surface. The distance for adjustment is denoted as z . We found that the value of z is constant and can be applied to any parabola. The magnitude of z can be obtained by considering all the variables in the dish (Figure4) based on the receiver surface diameter, then Figure4 can be made more detailed, as seen in Figure6.

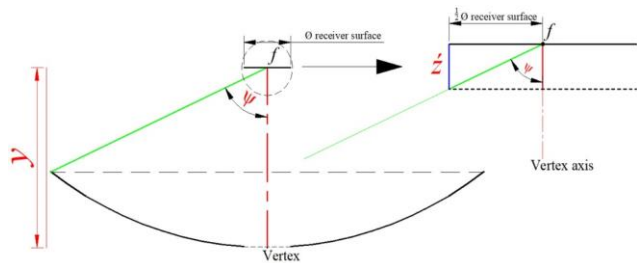

FIGURE 6.

DETAILED GEOMETRY OF THE CONCENTRATOR DISH WITH RECEIVER POSITION

The value of z is denoted as the length for adjusting the position of the receiver. It can be obtained from (2):

$$z = \frac{\frac{1}{2} \phi_{receiver\ surface}}{\tan\psi} \quad (2)$$

Once z is obtained, it can determine the receiver position's exact adjustment from the focal point. Referring to Figure6, the position of the receiver can be above or below the focal point with a precise position using (3):

$$IdealReceiverPosition = y \pm z \quad (3)$$

The relative sign (\pm) indicates the relative position for the adjustment. Sign (+) indicates that the position of receiver is above the focal point, and (-) for below the focal point. The value of z for adjusting the receiver position provides a vital reference for maximizing the absorption of sunlight on the receiver without changing the dish concentrator's geometry.

3.2. Experimental Validation of the z Value

Three different receiver positions based on the adjustment of z are tested experimentally. Tests are carried out to observe the heat absorption and temperature distribution pattern on the receiver surface with three different positions: at the focal point, above ($+z$) and beneath the focal point ($-z$). Each model is tested simultaneously by using three different prototypes to ensure the reliability of the test. After observing the pattern and temperature distribution, we set a schematic model of the absorbed heat on the receiver surface and the temperature range on each area.

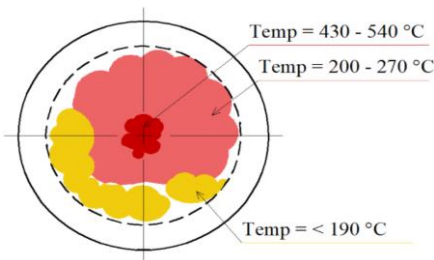

FIGURE 7.

THE ABSORBED HEAT ON THE RECEIVER SURFACE AT POSITION EXACT THE FOCAL POINT

Figure 7 shows the pattern of the absorbed heat on the receiver surface when the receiver is located precisely at the focal point. The dashed line is the diameter of the receiver. As it can be seen from Figure 7, the pattern of the absorbed heat indicates that the heat concentration only occurs in the center of the receiver (dark red, temperature ranging from 430–540 °C), and a scattered heat concentration (light red, with temperature ranging from 200 – 270 °C) occupy a larger area of the receiver. Partial heat absorption (dark-yellow, < 190 °C) indicates the lowest heat concentration. A high concentration in a small part of the receiver is a disadvantage because it may damage its surface area (melting). Furthermore, the uneven heat distribution reduces the possibility of heat transfer from the receiver surface.

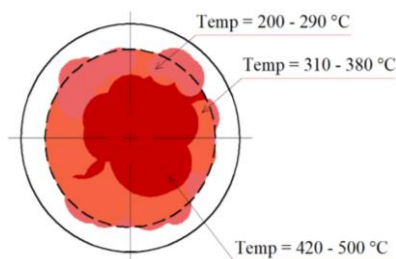

FIGURE 8.

THE ABSORBED HEAT ON THE RECEIVER SURFACE AT A POSITION BENEATH THE FOCAL POINT

Changing the receiver position according to the value of z shows a significant effect. Figure 8 shows the pattern when the receiver is located beneath the focal point ($-z$). The highest concentration area is more expansive and occupies most of the surface with a high temperature ranging from 420–500 °C (dark red). Even the maximum temperature is lower than the receiver at the focal point (Fig. 7), the heat is dispersed at a larger area of the receiver's surface, maximizing the heat transfer area for the actual receiver. The partial heat distribution (brown and dark red area) is located on the surface of the receiver with a suitable temperature. At this position, most of the receiver surface can absorb the incoming light concentration, minimizing losses.

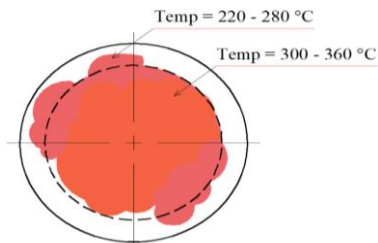

FIGURE 9.

THE ABSORBED HEAT ON THE RECEIVER SURFACE AT A POSITION ABOVE THE FOCAL POINT

Figure 9 has a different pattern than Figure 8 because the receiver's position on this model is above the focal point with an adjustment value of $+z$. The temperature distribution is generally lower, with no high concentration of the absorbed heat on the receiver surface (dark red). The receiver's position above the focal point causes the spread of sunlight to pass through the focal point, creating a collision on photons, thereby reducing the radiation speed and decreasing the absorbed heat on the receiver surface. A medium heat absorptance (light brown, with temperature ranging from 300–360 °C) dominates the entire receiver area, which is a clear indicator that this section can provide a more even distribution of heat but reduces the value of heat absorbed on the receiver surface due to a decrease in the radiation value of the reflected photons.

Experimental evaluation and observation of the absorbed heat pattern on the receiver surface (Fig. 7–9) provide better accuracy to prove that different receiver positions significantly influence the absorption model in the receiver [18]. Validation through experimental tests also provides an advantage where the actual value of the reflection of sunlight from the dish to the receiver is not distributed relatively due to the dish's geometrical defect, type of reflector, and the relative error due to the sun and earth tilt. The sunlight reflection pattern can be observed from the receiver heat absorption image (Fig. 7–9), where no perfectly round absorption model [19]. All models show partial absorption in certain areas where the receiver's position influences the absorption concentration value (at the focal point, above or beneath the focal point).

IV. CONCLUSIONS

The designed parabolic dish offers a flexible utilization with the possibility to employ TES on the system. The key finding of our study is the new approach for locating the receiver. The receiver's adjustment is made according to an equation that can precisely determine the exact receiver position by using the magnitude of \dot{z} . The value of \dot{z} is used as a constant reference to adjusting the receiver's ideal position from the focal point. The experimental verification at different receiver positions supports the offered adjustment through the equation is acceptable. The reference is expected to promote a better reference for further development in the parabolic dish system, both for direct and indirect illumination receivers. Further development of the proposed design focuses on the working fluid's heat absorption process and the analysis of the overall thermal efficiency.

REFERENCES

- Agalit, H., Zari, N., & Maaroufi, M. (2020). Suitability of industrial wastes for application as high temperature thermal energy storage (TES) materials in solar tower power plants – A comprehensive review. *Solar Energy*, 208(July), 1151–1165. <https://doi.org/10.1016/j.solener.2020.08.055>
- ALhsani, Z. I. A., & dulaimi, R. K. M. Al. (2020). Experimental Analysis of Solar Dish Concentrators with Cylindrical, Oval, and Conical Cavity Receivers. *International Journal of Renewable Energy Research*, 10(2), 591–600.
- Daabo, A. M., Bellos, E., Pavlovic, S., Bashir, M. A., Mahmoud, S., & Al-Dadah, R. K. (2020). Characterization of a micro thermal cavity receiver – Experimental and analytical investigation. *Thermal Science and Engineering Progress*, 18(March), 100554. <https://doi.org/10.1016/j.tsep.2020.100554>
- Fathabadi, H. (2020). Novel low-cost parabolic trough solar collector with TPCT heat pipe and solar tracker: Performance and comparing with commercial flat-plate and evacuated tube solar collectors. *Solar Energy*, 195(November 2019), 210–222. <https://doi.org/10.1016/j.solener.2019.11.057>
- Gogoi, T. K., & Saikia, S. (2019). Performance analysis of a solar heat driven organic Rankine cycle and absorption cooling system. *Thermal Science and Engineering Progress*, 13(June), 100372. <https://doi.org/10.1016/j.tsep.2019.100372>
- Hijazi, H., Mokhiemar, O., & Elsamni, O. (2016). Mechanical design of a low cost parabolic solar dish concentrator. *Alexandria Engineering Journal*, 55(1), 1–11. <https://doi.org/10.1016/j.aej.2016.01.028>
- Huang, W., & Marefati, M. (2020). Energy, exergy, environmental and economic comparison of various solar thermal systems using water and Therminol B base fluids, and CuO and Al₂O₃ nanofluids. *Energy Reports*, 6, 2919–2947. <https://doi.org/10.1016/j.egyr.2020.10.021>
- Ismail, I., Rahman, R. A., Haryanto, G., & Pane, E. A. (2021). The Optimal Pitch Distance for Maximizing the Power Ratio for Savonius Turbine on Inline Configuration. *International Journal of Renewable Energy Research*, 11(2), 595–599.
- Ismail, Pane, E. A., Haryanto, G., Okviyanto, T., & Rahman, R. A. (2021). A Better Approach for Modified Bach-Type Savonius Turbine Optimization [Research-article]. *International Review of Aerospace Engineering (IREASE)*, 14(3), 159–165. <https://doi.org/10.15866/irease.v14i3.20612>

- López, O., Baños, A., & Arenas, A. (2020). On the thermal performance of flat and cavity receivers for a parabolic dish concentrator and low/medium temperatures. *Solar Energy*, 199(July), 911–923. <https://doi.org/10.1016/j.solener.2019.07.056>
- Madadi Avargani, V., Rahimi, A., Divband, M., & Zamani, M. A. (2020). Optical analysis and heat transfer modeling of a helically baffled cavity receiver under solar flux non-uniformity and windy conditions. *Thermal Science and Engineering Progress*, 20(September), 100719. <https://doi.org/10.1016/j.tsep.2020.100719>
- Mehrpooya, M., Ghorbani, B., & Moradi, M. (2019). A novel MCFC hybrid power generation process using solar parabolic dish thermal energy. *International Journal of Hydrogen Energy*, 44(16), 8548–8565. <https://doi.org/10.1016/j.ijhydene.2018.12.014>
- Mosbah, C. A., Tadjine, M., Chakir, M., & Boucherit, M. S. (2016). On the control of parabolic solar collector: The zipper approach. *International Journal of Renewable Energy Research*, 6(3), 1100–1108.
- Rahmalina, D., Rahman, R. A., Suwandi, A., & Ismail. (2020). The recent development on MgH₂ system by 16 wt% nickel addition and particle size reduction through ball milling: A noticeable hydrogen capacity up to 5 wt% at low temperature and pressure. *International Journal of Hydrogen Energy*, 45(53), 29046–29058. <https://doi.org/10.1016/j.ijhydene.2020.07.209>
- Singh, U. R., & Kumar, A. (2018). Review on solar Stirling engine: Development and performance. *Thermal Science and Engineering Progress*, 8(August), 244–256. <https://doi.org/10.1016/j.tsep.2018.08.016>
- Soltani, S., Bonyadi, M., & Madadi Avargani, V. (2019). A novel optical-thermal modeling of a parabolic dish collector with a helically baffled cylindrical cavity receiver. *Energy*, 168, 88–98. <https://doi.org/10.1016/j.energy.2018.11.097>
- Song, X., Deng, Z., Guo, H., Liu, R., Li, L., & Liu, R. (2017). Networking of Bennett linkages and its application on deployable parabolic cylindrical antenna. *Mechanism and Machine Theory*, 109(October 2016), 95–125. <https://doi.org/10.1016/j.mechmachtheory.2016.10.019>
- Weinstein, L. A., Loomis, J., Bhatia, B., Bierman, D. M., Wang, E. N., & Chen, G. (2015). Concentrating Solar Power. *Chemical Reviews*, 115(23), 12797–12838. <https://doi.org/10.1021/acs.chemrev.5b00397>
- Yazdanipour, T., Shahraki, F., & Mohebbi Kalhori, D. (2020). Experimental Analysis of Free Convection Heat Loss in a Bicylindrical Cavity Receiver. *Thermal Science and Engineering Progress*, 100663. <https://doi.org/10.1016/j.tsep.2020.100663>

AUTHOR INFORMATION

DwiRahmalina, Associate Professor, Department of Mechanical Engineering, Universitas Pancasila
Reza Abdu Rahman, Instructor, Department of Mechanical Engineering, Universitas Pancasila
Octavian Yudhistira, Bachelor of Engineering Student, Department of Mechanical Engineering, Universitas Pancasila
Agri Suwandi, Assistant Professor, Department of Mechanical Engineering, Universitas Pancasila